



BENTON COUNTY FIRE PROTECTION DISTRICT NO. 4 REGULAR BOARD AGENDA

July 18, 2019
2604 Bombing Range Rd.
West Richland WA. 99353

CALL MEETING TO ORDER

PLEDGE OF ALLEGIANCE

ADDITION TO THE AGENDA

THOSE PRESENT:

FINANCIAL REVIEW

CONSENT AGENDA:

(All matters listed within the Consent Agenda have been distributed to each member of the Board of Commission for reading and study, are considered to be routine, and will be considered or enacted by one motion of the Commission with no separate discussion. If separate discussion is desired, that item may be removed from the Consent Agenda and placed on the Regular Agenda by request.)

- Approval of the Agenda dated 07/18/2019
- Approval of Regular Meeting Minutes dated 07/03/2019
- Approval and pay:
- **Expenditures:**

522 Fire Control	73,638.69
589 Payroll Clearing	23,446.10
<u>001 General Fund</u>	<u>97,084.79</u>

594 Capital Expenditures	455.00
<u>401 Construction Fund</u>	<u>455.00</u>

- **EFT**

522 Fire Control	137,824.04
589 Payroll Clearing	-42,062.02
<u>001 General Fund</u>	<u>95,762.02</u>

- **Key Bank Tax Deposit**

522 Fire Control	3,136.95
589 Payroll Clearing	18,564.53
<u>001 General Fund</u>	<u>21,701.48</u>

Total: \$215,003.29

RESOLUTIONS/MOTIONS

- Resolution 2019-03: Equipment Surplus

DISTRICT REPORTS

- Union Report
- Volunteer Report
- Logistics Report
- City Liaison Report
- Commissioner's Report
- Fire Chief's Report
- District Secretary's Report

OPEN FORUM DISCUSSION

IMPORTANT DATES

- August 6 – National Night Out
- October 12 – BCFD4 Open House

CORRESPONDENCE

AMBULANCE SERVICE PROGRAM UPDATES

UNFINISHED BUSINESS

- Fire Department Community Assistance, Referrals and Education Services (FDCARES) program
- Station Design Team
- Apparatus Committee

NEW BUSINESS

AGENDA ITEMS FOR NEXT MEETING

EXECUTIVE SESSION

ADJOURNMENT:

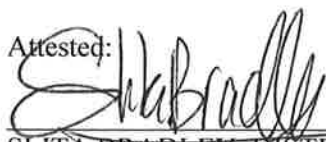
Attested:  07.18.19
SLITA BRADLEY, DISTRICT SECRETARY

 07.18.19
GREGG COUCH, COMMISSIONER

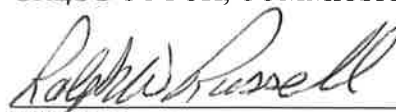
 07.18.19
WOODY RUSSELL, COMMISSIONER

 7.18.2019
AJ HILL, COMMISSIONER



BENTON COUNTY FIRE PROTECTION DISTRICT NO. 4 REGULAR BOARD MEETING MINUTES

July 3, 2019
2604 Bombing Range Rd.
West Richland WA. 99353

CALL MEETING TO ORDER

Commissioner Couch called the meeting to order at 1801 hrs.

PLEDGE OF ALLEGIANCE

- Commissioner Russell led the pledge of allegiance.

ADDITION TO THE AGENDA

- Resolution 2019-02: Equipment Surplus
- SOG 1013 Ride Along Program

THOSE PRESENT:

Commissioner Woody Russell
Commissioner AJ Hill
Commissioner Gregg Couch
Fire Chief William Whealan
District Secretary Slita Bradley
Captain Robert Shannon
Lieutenant Tom Harper
Firefighter Garrett Goodwin
Firefighter Chris Yaroch

Firefighter Ryan Sommerville
Logistics Ed Caraway
Firefighter Sam Monds
Logistics Caren Davis
Firefighter James Longie
Firefighter Monte Elmore
City Liaison Fred Brink
Firefighter Kyle Jagelski
Firefighter Martin Fitzhugh

FINANCIAL REVIEW

- Reviewed with no questions.

CONSENT AGENDA:

(All matters listed within the Consent Agenda have been distributed to each member of the Board of Commission for reading and study, are considered to be routine, and will be considered or enacted by one motion of the Commission with no separate discussion. If separate discussion is desired, that item may be removed from the Consent Agenda and placed on the Regular Agenda by request.)

- Approval of the Agenda dated 07/03/2019
- Approval of Regular Meeting Minutes dated 06/19/2019
- Approval and pay:
- **Expenditures:**

522 Fire Control	43,783.35
<u>001 General Fund</u>	<u>43,783.35</u>

522 Fire Control	3,016.04
<u>110 EMS Fund</u>	<u>3,016.04</u>

594 Capital Expenditures	19,678.75
<u>401 Construction Fund</u>	<u>19,678.75</u>

Total: \$66,478.14

Commissioner Hill made a motion to approve the consent agenda, seconded by Commissioner Russell and the motion carried.

RESOLUTIONS/MOTIONS

- Resolution 2019-02: Equipment Surplus
 - Chief Whealan reported that to address Washington Survey and Ratings Bureau (WSRB) concerns, a pumper can be shared as a reserve unit with other agencies in the area with a written agreement with a bordering agency.

Commissioner Hill made a motion to approve Resolution 2019-02, seconded by Commissioner Russell and the motion carried.

- SOG 1013: Ride Along Program
 - Commissioner Couch asked if the district runs a criminal background check on ride-along participants. Chief Whealan reported that the district currently did not. Commissioner Couch would like to see a background check done on a ride-along in case they were criminals.

Commissioner Hill made a motion to approve SOG 1013 with the added appropriate background investigation, seconded by Commissioner Russell and the motion carried.

- Lieutenant Longie asked if the background check should be run every single time ride-along participants scheduled a ride along. It can be costly since they can schedule a ride-along twice a month.
- Captain Shannon will update the SOG and send to Chief Whealan for approval.

Commissioner Hill amended his motion to add running background checks on ride-along participants annually, seconded by Commissioner Russell and the motion carried.

DISTRICT REPORTS

- Union Report
 - No report.
- Volunteer Report
 - Volunteer Training Officer Jagelski reported that the BBQ party starts at 1700 on 07/04/2019.
- Logistics Report
 - No report-
- City Liaison Report
 - City Liaison Brink reported that on 08/06/2019 from 5-8 pm is the National Night Out event at Flat Top Park.
 - City Liaison Brink will not be available for the next regular meeting but will ask Councilmember Fetto to attend in his place.
- Commissioner's Report
 - No report.
- Fire Chief's Report
 - He attended the Hogs and Dogs event. The weather was nice, and the event was well attended.

- He attended Ed Keeney's wife's Celebration of Life with Lieutenant Meloy and Resident Johnson. It was well attended.
- He had a conference call with ZBA Architecture and the Station #430 Design Team to work out further details on the design.
- He attended the BCFD4 Executive Staff meeting, and the notes have been forwarded along and posted on the server.
- He assisted with standby at the Partners and Pals event with District Secretary Bradley, Logistics Members Lucas and Smith. The event coordinator was thankful to have a standby ambulance.
- He met with Lieutenant Longie to prioritize some of his facilities projects.
- District Secretary's Report
 - No report

OPEN FORUM DISCUSSION

- Firefighter Yaroch made a suggestion to the board that when the district exceeds E1452, please consider donating it to BCFD5. Chief Whealan suggested Firefighter Yaroch coordinate with Captain Newton in case he wants to auction it off. Commissioner Hill stated that the district can excess the truck and Tri-County Commissioners can determine who has the most need for the truck.

IMPORTANT DATES

- July 4 – Independence Day
- August 6 – National Night Out, 5-8 pm, at Flat Top Park.

CORRESPONDENCE

- No correspondence

AMBULANCE SERVICE PROGRAM UPDATES

- No updates

UNFINISHED BUSINESS

- Fire Department Community Assistance, Referrals and Education Services (FDCARES) program
 - No report
- Station Design Team
 - Commissioner Russell reported that the district received cost estimates ranging from low to high. Baseline cost estimate was within the budget. The bids should be going out by the end of July or the beginning of August.
- Apparatus Committee
 - Commissioner Hill reported that the committee received specifications for rescue/pumper engines and an aerial. Captain Newton sent the specifications out to everyone for review.

NEW BUSINESS

- No new business

AGENDA ITEMS FOR NEXT MEETING

- Fire Department Community Assistance, Referrals and Education Services (FDCARES) program
- Station Design Team

- Apparatus Committee

EXECUTIVE SESSION

- No sessions.

ADJOURNMENT:

The meeting was adjourned at 1825 hrs.

Attested:

 07/18/19
SLITA BRADLEY, DISTRICT SECRETARY

 07/18/19
GREGG COUCH, COMMISSIONER

 07/18/2019
WOODY RUSSELL, COMMISSIONER

 07/18/2019
AJ HILL, COMMISSIONER

2019 BUDGET POSITION

BENTON COUNTY FIRE PROTECTION L
 MCAG #: 1040

Time: 15:35:54 Date: 07/17/2019
 Page: 1

01/01/2019 To: 12/31/2019

001 General Fund

Revenues	Amt Budgeted	Revenues	Remaining	
308 Beginning Balances				
308 80 00 00 Beginning Balance	1,611,919.42	1,611,919.42	0.00	100.0%
308 Beginning Balances	1,611,919.42	1,611,919.42	0.00	100.0%
310 Taxes				
311 10 00 01 Property Tax	2,432,971.00	1,378,514.18	1,054,456.82	56.7%
337 20 00 01 Leasehold Tax	27,500.00	32,626.01	(5,126.01)	118.6%
310 Taxes	2,460,471.00	1,411,140.19	1,049,330.81	57.4%
330 Intergovernmental Revenues				
331 15 22 81 U.S. Fish & Wildlife Grant	0.00	0.00	0.00	0.0%
331 97 04 40 AFG GRANT	0.00	0.00	0.00	0.0%
331 97 08 34 SAFER Grant	0.00	0.00	0.00	0.0%
334 01 30 02 WSP-FF Training	1,000.00	0.00	1,000.00	0.0%
334 04 90 01 State Trauma Grant	1,200.00	1,266.00	(66.00)	105.5%
334 06 90 04 BVFF Physical Reimb.	1,000.00	700.00	300.00	70.0%
335 00 91 01 Energy NW Generation T	25,000.00	0.00	25,000.00	0.0%
337 97 04 40 AFG COST SHARE	0.00	0.00	0.00	0.0%
330 Intergovernmental Revenues	28,200.00	1,966.00	26,234.00	7.0%
340 Charges For Services				
341 70 00 05 Resale/Supply Merchandise	0.00	0.00	0.00	0.0%
342 21 00 01 Fire Services, State	39,000.00	17,719.76	21,280.24	45.4%
342 21 00 02 Fire Services, Federal	0.00	0.00	0.00	0.0%
342 21 00 03 Fire Services, Schools	2,300.00	0.00	2,300.00	0.0%
342 21 00 04 Private Fire Service-Other	0.00	0.00	0.00	0.0%
342 21 00 09 Fire Services, W Rhld	0.00	0.00	0.00	0.0%
340 Charges For Services	41,300.00	17,719.76	23,580.24	42.9%
350 Fines & Forfeitures				
359 90 00 01 Fines And Penalties	0.00	0.00	0.00	0.0%
350 Fines & Forfeitures	0.00	0.00	0.00	0.0%
360 Investment Interest				
361 11 00 01 Investment Interest	2,000.00	12,825.74	(10,825.74)	641.3%
367 11 00 08 Contributions/Donation	0.00	0.00	0.00	0.0%
369 10 05 01 Sale Of Scrap & Junk	0.00	0.00	0.00	0.0%
369 40 00 02 Judgements And Settlements	0.00	0.00	0.00	0.0%
369 91 00 00 Other Miscellaneous Revenue	22,000.00	21,548.17	451.83	97.9%
360 Investment Interest	24,000.00	34,373.91	(10,373.91)	143.2%
380 Non Revenues				
389 00 00 01 Suspense- To Be Reclassified	0.00	0.00	0.00	0.0%
389 50 68 04 Refund/Reimbursement	0.00	0.00	0.00	0.0%

2019 BUDGET POSITION

BENTON COUNTY FIRE PROTECTION I
 MCAG #: 1040

Time: 15:35:54 Date: 07/17/2019
 Page: 2

01/01/2019 To: 12/31/2019

001 General Fund

Revenues	Amt Budgeted	Revenues	Remaining	
380 Non Revenues				
380 Non Revenues	0.00	0.00	0.00	0.0%
390 Other Revenues				
395 10 00 02 Sale Of Fixed Assets	0.00	0.00	0.00	0.0%
395 20 00 01 Comp For Loss Of Assets	0.00	0.00	0.00	0.0%
390 Other Revenues	0.00	0.00	0.00	0.0%
397 Interfund Transfers				
397 00 00 01 Transfer In	0.00	0.00	0.00	0.0%
397 00 00 10 Transfer In From 110	857,884.00	0.00	857,884.00	0.0%
397 00 01 06 Transfer In From 601	0.00	0.00	0.00	0.0%
397 00 01 07 Transfer In From 107	0.00	0.00	0.00	0.0%
397 00 02 01 Transfer In From 202	0.00	0.00	0.00	0.0%
397 00 05 01 Transfer In From 501	0.00	0.00	0.00	0.0%
397 Interfund Transfers	857,884.00	0.00	857,884.00	0.0%

Fund Revenues:	5,023,774.42	3,077,119.28	1,946,655.14	61.3%
-----------------------	---------------------	---------------------	---------------------	--------------

Expenditures	Amt Budgeted	Expenditures	Remaining	
522 Fire Control				
522 11 10 10 Salary - Comm 1 (Couch)	5,000.00	2,276.00	2,724.00	45.5%
522 11 10 20 Salary-Comm 2 (Russell)	5,000.00	2,902.00	2,098.00	58.0%
522 11 10 30 Salary-Comm 3 (Hill)	5,000.00	2,532.00	2,468.00	50.6%
522 11 20 10 Benefits - Comm 1 (Couch)	500.00	180.89	319.11	36.2%
522 11 20 20 Benefits - Comm 2 (Russell)	500.00	228.43	271.57	45.7%
522 11 20 30 Benefits - Comm 3 (Hill)	500.00	199.63	300.37	39.9%
522 11 31 00 Expendable Supplies- Legislative	0.00	0.00	0.00	0.0%
522 11 43 00 Travel-Mileage & Airfare	1,100.00	0.00	1,100.00	0.0%
522 11 43 30 Travel - Per Diem & Lodging	2,500.00	1,218.76	1,281.24	48.8%
522 11 43 31 Registration Fees	2,000.00	510.00	1,490.00	25.5%
011 Legislative	22,100.00	10,047.71	12,052.29	45.5%
522 12 10 10 Salary - Administration	220,420.00	121,988.83	98,431.17	55.3%
522 12 10 60 Overtime - Administrative	6,500.00	0.00	6,500.00	0.0%
522 12 10 70 Temporary Employees	0.00	0.00	0.00	0.0%
522 12 20 04 HRA Benefits	6,000.00	3,500.00	2,500.00	58.3%
522 12 20 10 Benefits - Administrative	58,450.00	36,494.66	21,955.34	62.4%
522 12 20 60 Benefits - OT Administration	1,800.00	0.00	1,800.00	0.0%
522 12 20 70 Benefits - Temporary Employees	0.00	0.00	0.00	0.0%
522 12 24 20 Volunteer Pension & Relief Fund	6,000.00	2,730.00	3,270.00	45.5%
522 12 29 20 Volunteer Recognition	4,000.00	2,845.74	1,154.26	71.1%
522 12 29 30 Volunteer Association	3,500.00	3,499.35	0.65	100.0%
522 12 31 00 Expendable Office Supplies	3,750.00	970.06	2,779.94	25.9%
522 12 31 10 Computer Software	0.00	0.00	0.00	0.0%
522 12 35 00 Office Tools & Equipment	2,000.00	595.04	1,404.96	29.8%
522 12 35 10 Office Computer Equipment	12,000.00	8,072.94	3,927.06	67.3%
522 12 41 00 Contract Services	63,000.00	19,418.42	43,581.58	30.8%

2019 BUDGET POSITION

BENTON COUNTY FIRE PROTECTION C
 MCAG #: 1040

Time: 15:35:54 Date: 07/17/2019
 Page: 3

001 General Fund 01/01/2019 To: 12/31/2019

Expenditures	Amt Budgeted	Expenditures	Remaining	
522 Fire Control				
522 12 41 01	FAC Lease and Services	2,000.00	0.00	2,000.00 0.0%
522 12 41 02	Contract For Union Negotiation	20,000.00	0.00	20,000.00 0.0%
522 12 41 10	Financial Services Contract(BIAS)	14,852.00	12,173.54	2,678.46 82.0%
522 12 41 20	Professional Services	10,000.00	150.00	9,850.00 1.5%
522 12 42 00	Phone Service	4,200.00	3,068.26	1,131.74 73.1%
522 12 42 10	Cellular Phone Service	10,000.00	4,976.17	5,023.83 49.8%
522 12 42 20	Pagers Service	0.00	0.00	0.00 0.0%
522 12 42 40	Postage	1,500.00	292.88	1,207.12 19.5%
522 12 42 41	Postage For Warrants	0.00	0.00	0.00 0.0%
522 12 44 00	Advertising/Notices/Recruiting	1,500.00	352.00	1,148.00 23.5%
522 12 45 00	Equipment Lease/Maint	3,400.00	1,853.86	1,546.14 54.5%
522 12 46 00	District Insurance	40,000.00	1,160.00	38,840.00 2.9%
522 12 48 00	Repair & Maint. - Office Equip	0.00	0.00	0.00 0.0%
522 12 48 20	WebPage Maintenance	500.00	0.00	500.00 0.0%
522 12 49 00	Memberships/Dues	16,000.00	14,974.12	1,025.88 93.6%
522 12 49 10	Taxes And Irrigation Fees	50.00	55.70	(5.70) 111.4%
522 12 49 20	State Auditor	6,000.00	0.00	6,000.00 0.0%
012 Administrative		517,422.00	239,171.57	278,250.43 46.2%
522 13 41 00	Levy Publication Services	45,000.00	20,036.91	24,963.09 44.5%
522 13 48 20	Outside Services	0.00	0.00	0.00 0.0%
522 13 49 00	Commissioner Elections	5,000.00	0.00	5,000.00 0.0%
013 Election		50,000.00	20,036.91	29,963.09 40.1%
522 14 41 00	Legal Services	24,000.00	9,823.00	14,177.00 40.9%
014 Legal		24,000.00	9,823.00	14,177.00 40.9%
522 15 40 00	Advance Travel/Petty Cash	0.00	0.00	0.00 0.0%
015 Internal Acct		0.00	0.00	0.00 0.0%
522 20 10 10	Mobilization Wages	30,000.00	3,435.20	26,564.80 11.5%
522 20 20 10	Mobilization Benefits	9,000.00	573.68	8,426.32 6.4%
522 20 24 10	Physicals/Innoculation	63,000.00	21,657.00	41,343.00 34.4%
522 20 28 00	Uniforms (All Non-PPE)	10,000.00	7,759.18	2,240.82 77.6%
522 20 31 00	Expendable Incident Supplies	500.00	153.25	346.75 30.7%
522 20 35 00	Tools & Equipment	500.00	0.00	500.00 0.0%
522 20 35 20	Physical Eval Equipment	3,000.00	0.00	3,000.00 0.0%
522 20 41 00	Assessment Fees	6,000.00	0.00	6,000.00 0.0%
522 20 48 00	Uniform Maintenance	2,000.00	0.00	2,000.00 0.0%
020 Operations		124,000.00	33,578.31	90,421.69 27.1%
522 21 10 10	Salary - Firefighters	1,200,676.00	696,353.70	504,322.30 58.0%
522 21 10 71	Overtime - Firefighters	100,000.00	56,961.35	43,038.65 57.0%
522 21 10 80	Resident Reimbursement	105,600.00	28,671.00	76,929.00 27.2%
522 21 10 90	Volunteer Reimbursement	66,000.00	23,229.00	42,771.00 35.2%
522 21 20 04	HRA Benefits	42,000.00	24,500.00	17,500.00 58.3%
522 21 20 10	Benefits - Firefighters	362,716.77	219,174.03	143,542.74 60.4%
522 21 20 71	Benefits - Overtime FF	37,500.00	16,460.17	21,039.83 43.9%
522 21 20 80	Benefits - Resident Reimbursement	3,000.00	2,193.34	806.66 73.1%
522 21 20 90	Benefits - Volunteer	3,500.00	1,910.79	1,589.21 54.6%
522 21 28 20	PPE - Protective Clothing	50,000.00	11,735.35	38,264.65 23.5%
522 21 31 00	Expendable Supplies - Suppression	3,600.00	161.86	3,438.14 4.5%

2019 BUDGET POSITION

BENTON COUNTY FIRE PROTECTION C
 MCA# #: 1040

Time: 15:35:54 Date: 07/17/2019

Page: 4

001 General Fund

01/01/2019 To: 12/31/2019

Expenditures	Amt Budgeted	Expenditures	Remaining	
522 Fire Control				
522 21 31 10	Supplies - Support Service	4,000.00	570.36	3,429.64 14.3%
522 21 35 10	Tools & Equipment -Suppression	5,000.00	502.12	4,497.88 10.0%
522 21 35 11	Hose Replacement	2,000.00	0.00	2,000.00 0.0%
522 21 35 12	Nozzle Replacement	3,500.00	0.00	3,500.00 0.0%
522 21 35 13	Tools - Support Service	7,200.00	0.00	7,200.00 0.0%
522 21 41 00	Professional Services	11,000.00	683.81	10,316.19 6.2%
522 21 48 00	Equipment Repair & Maint	1,550.00	0.00	1,550.00 0.0%
522 21 48 10	Fire Extinguisher Maint	850.00	0.00	850.00 0.0%
522 21 48 80	SCBA Air Compressor	0.00	0.00	0.00 0.0%
522 21 48 90	SCBA Repair/Maintenance	1,000.00	91.65	908.35 9.2%
021 Suppression	2,010,692.77	1,083,198.53	927,494.24	53.9%
522 24 31 00	Expendable Supplies - Radios	1,000.00	43.39	956.61 4.3%
522 24 35 00	Non-Expendable Supplies - Radios	8,000.00	5,668.26	2,331.74 70.9%
522 24 41 00	Dispatch Services	63,366.00	36,963.50	26,402.50 58.3%
522 24 41 10	VHF Maintenance Fee	15,000.00	0.00	15,000.00 0.0%
522 24 48 00	Repair & Maintenance - Radios	1,000.00	162.74	837.26 16.3%
024 Communications	88,366.00	42,837.89	45,528.11	48.5%
522 30 31 00	Expendable Supplies-Prevention	2,500.00	0.00	2,500.00 0.0%
522 30 31 10	Smoke Alarm Program	300.00	0.00	300.00 0.0%
522 30 35 00	Tools & Equipment - Prevention	750.00	0.00	750.00 0.0%
522 30 48 00	Repair & Maintenance - Prevention	0.00	0.00	0.00 0.0%
522 30 48 10	Newsletter/Education Flyers	100.00	0.00	100.00 0.0%
030 Public Information	3,650.00	0.00	3,650.00	0.0%
522 45 31 00	Expendable Supplies - Training	2,000.00	143.92	1,856.08 7.2%
522 45 31 10	Training Computer Software	8,700.00	6,495.40	2,204.60 74.7%
522 45 35 00	Tools & Equipment - Training	1,800.00	335.28	1,464.72 18.6%
522 45 35 10	Equipment- Wellness Program	0.00	0.00	0.00 0.0%
522 45 41 00	Professional Service	14,000.00	4,000.00	10,000.00 28.6%
522 45 43 00	Travel - Mileage & Air(Operations)	3,500.00	174.40	3,325.60 5.0%
522 45 43 01	Travel - Mileage&Air(Admin)	2,400.00	83.52	2,316.48 3.5%
522 45 43 02	Travel - Mileage&Air(Automotive)	50.00	0.00	50.00 0.0%
522 45 43 03	Travel - Mileage&Air(EMS Officer)	6,500.00	960.00	5,540.00 14.8%
522 45 43 10	PerDiem & Lodging(Operations)	8,000.00	3,583.63	4,416.37 44.8%
522 45 43 11	PerDiem & Lodging(Admin)	6,800.00	1,054.93	5,745.07 15.5%
522 45 43 12	PerDiem & Lodging(Automotive)	600.00	0.00	600.00 0.0%
522 45 43 13	PerDiem & Lodging(EMS Officer)	8,000.00	2,450.46	5,549.54 30.6%
522 45 43 20	Registration Fees(Operations)	60,000.00	32,371.00	27,629.00 54.0%
522 45 43 21	Registration Fees(Admin)	3,500.00	670.00	2,830.00 19.1%
522 45 43 22	Registration Fees(Automotive)	600.00	0.00	600.00 0.0%
522 45 43 23	Registration Fees(EMS Officer)	6,500.00	2,425.00	4,075.00 37.3%
522 45 43 30	Tuition Reimbursement	5,000.00	2,200.00	2,800.00 44.0%
522 45 48 00	Repair And Maintenance	0.00	0.00	0.00 0.0%
045 Training	137,950.00	56,947.54	81,002.46	41.3%
522 50 31 00	Expendable Supplies -Facilities	6,500.00	2,162.55	4,337.45 33.3%
522 50 35 00	Tools & Equipment - Facilities	5,000.00	9,396.34	(4,396.34) 187.9%
522 50 41 00	Professional Services	0.00	0.00	0.00 0.0%
522 50 45 00	Lease-Sta 410	5,000.00	4,767.63	232.37 95.4%
522 50 47 10	Electricity	22,000.00	10,867.75	11,132.25 49.4%

2019 BUDGET POSITION

BENTON COUNTY FIRE PROTECTION D
 MCAG #: 1040

Time: 15:35:54 Date: 07/17/2019

Page: 5

001 General Fund

01/01/2019 To: 12/31/2019

Expenditures	Amt Budgeted	Expenditures	Remaining	
522 Fire Control				
522 50 47 20 Water/Sewer	10,000.00	2,795.26	7,204.74	28.0%
522 50 48 00 Repair & Maint. - Facilities	20,000.00	16,294.74	3,705.26	81.5%
050 Facilities	68,500.00	46,284.27	22,215.73	67.6%
522 60 31 00 Expendable Supplies - Automotive	6,000.00	2,941.23	3,058.77	49.0%
522 60 32 00 Fuels	25,000.00	10,712.53	14,287.47	42.9%
522 60 35 00 Tools & Equipment - Automotive	1,750.00	1,773.12	(23.12)	101.3%
522 60 48 00 Repair & Maint. - Automotive	52,440.00	35,403.51	17,036.49	67.5%
060 Automotive	85,190.00	50,830.39	34,359.61	59.7%
522 70 31 00 Expendable Supplies - EMS	25,000.00	20,910.67	4,089.33	83.6%
522 70 35 00 Small Tools & Minor Equip	4,000.00	445.71	3,554.29	11.1%
522 70 41 02 EMS Assessment Fee	1,500.00	986.11	513.89	65.7%
522 70 41 10 Contract Services - EMS	9,500.00	4,667.49	4,832.51	49.1%
522 70 48 00 Small Tools- Repairs & Maintenance	0.00	0.00	0.00	0.0%
526 22 31 01 Expendable Supplies - ALS	0.00	0.00	0.00	0.0%
070 EMS	40,000.00	27,009.98	12,990.02	67.5%
522 Fire Control	3,171,870.77	1,619,766.10	1,552,104.67	51.1%
588 Prior Period Adjustment				
585 10 00 01 Other Decreases In Net Cash & Investments - Other Costs Allocations	0.00	0.00	0.00	0.0%
588 Prior Period Adjustment	0.00	0.00	0.00	0.0%
589 Payroll Clearing				
589 90 00 00 Payroll Clearing	0.00	(51.39)	51.39	0.0%
589 90 00 01 Other Non-Expenditures - Suspense	0.00	0.00	0.00	0.0%
589 Payroll Clearing	0.00	(51.39)	51.39	0.0%
591 Debt Service				
591 22 71 02 Capital Lease Principal	492,587.00	492,586.87	0.13	100.0%
592 22 83 02 Capital Lease Interest	17,242.41	17,242.41	0.00	100.0%
591 Debt Service	509,829.41	509,829.28	0.13	100.0%
594 Capital Expenditures				
594 22 63 01 Capital Equipment - AFG Portion	0.00	0.00	0.00	0.0%
594 22 63 02 Capital Equipment - District Matching Portion	0.00	0.00	0.00	0.0%
000	0.00	0.00	0.00	0.0%
594 22 62 00 Captial Building	10,000.00	0.00	10,000.00	0.0%
594 22 63 00 Capital Apparatus And Equipment	0.00	0.00	0.00	0.0%
594 22 64 01 Capital Communications	0.00	0.00	0.00	0.0%

2019 BUDGET POSITION

BENTON COUNTY FIRE PROTECTION E
 MCAG #: 1040

Time: 15:35:54 Date: 07/17/2019

Page: 6

001 General Fund 01/01/2019 To: 12/31/2019

Expenditures	Amt Budgeted	Expenditures	Remaining	
594 Capital Expenditures				
022 Capital	10,000.00	0.00	10,000.00	0.0%
594 Capital Expenditures	10,000.00	0.00	10,000.00	0.0%
597 Interfund Transfers				
597 00 00 01 Transfers Out To 501	0.00	0.00	0.00	0.0%
597 00 01 04 Transfer Out	0.00	0.00	0.00	0.0%
597 00 01 05 Transfer Out	0.00	0.00	0.00	0.0%
597 00 01 07 Transfers-Out To 107	50,000.00	50,000.00	0.00	100.0%
597 00 01 61 Transfer Out To 601	48,584.00	48,584.00	0.00	100.0%
597 Interfund Transfers	98,584.00	98,584.00	0.00	100.0%
Fund Expenditures:	3,790,284.18	2,228,127.99	1,562,156.19	58.8%
Fund Excess/(Deficit):	1,233,490.24	848,991.29		

2019 BUDGET POSITION

BENTON COUNTY FIRE PROTECTION E
 MCAG #: 1040

Time: 15:35:54 Date: 07/17/2019
 Page: 7

004 Health Reimbursement Fund

01/01/2019 To: 12/31/2019

Revenues	Amt Budgeted	Revenues	Remaining	
308 Beginning Balances				
308 10 00 04 Beginning Balance	83.10	83.10	0.00	100.0%
308 Beginning Balances	83.10	83.10	0.00	100.0%
340 Charges For Services				
349 17 00 01 Employee Benefit - HRA	0.00	0.00	0.00	0.0%
340 Charges For Services	0.00	0.00	0.00	0.0%
360 Investment Interest				
361 11 00 04 Investment Interest	0.00	0.60	(0.60)	0.0%
360 Investment Interest	0.00	0.60	(0.60)	0.0%
380 Non Revenues				
388 80 00 01 Prior Year(s) Corrections	0.00	0.00	0.00	0.0%
380 Non Revenues	0.00	0.00	0.00	0.0%
397 Interfund Transfers				
397 00 01 04 Transfer In From 001	0.00	0.00	0.00	0.0%
397 00 01 05 Transfer In From 101	0.00	0.00	0.00	0.0%
397 Interfund Transfers	0.00	0.00	0.00	0.0%
Fund Revenues:	83.10	83.70	(0.60)	100.7%
Fund Excess/(Deficit):	83.10	83.70		

2019 BUDGET POSITION

BENTON COUNTY FIRE PROTECTION E
 MCAG #: 1040

Time: 15:35:54 Date: 07/17/2019

Page: 8

007 Separation Fund 01/01/2019 To: 12/31/2019

	Amt Budgeted	Revenues	Remaining	
--	--------------	----------	-----------	--

308 Beginning Balances

308 80 00 07 Beginning Balance	10,087.24	10,087.24	0.00	100.0%
308 Beginning Balances	10,087.24	10,087.24	0.00	100.0%

360 Investment Interest

361 11 00 07 Investment Interest	0.00	117.96	(117.96)	0.0%
360 Investment Interest	0.00	117.96	(117.96)	0.0%

397 Interfund Transfers

397 00 00 07 Transfer In From 001	50,000.00	50,000.00	0.00	100.0%
397 Interfund Transfers	50,000.00	50,000.00	0.00	100.0%

Fund Revenues:	60,087.24	60,205.20	(117.96)	100.2%
-----------------------	------------------	------------------	-----------------	---------------

	Amt Budgeted	Expenditures	Remaining	
--	--------------	--------------	-----------	--

597 Interfund Transfers

597 00 00 07 Transfers-Out To 001	0.00	0.00	0.00	0.0%
597 Interfund Transfers	0.00	0.00	0.00	0.0%

Fund Expenditures:	0.00	0.00	0.00	0.0%
---------------------------	-------------	-------------	-------------	-------------

Fund Excess/(Deficit):	60,087.24	60,205.20		
-------------------------------	------------------	------------------	--	--

2019 BUDGET POSITION

BENTON COUNTY FIRE PROTECTION
 MCAG #: 1040

Time: 15:35:54 Date: 07/17/2019
 Page: 9

110 EMS Fund 01/01/2019 To: 12/31/2019

	Amt Budgeted	Revenues	Remaining	
--	--------------	----------	-----------	--

308 Beginning Balances

308 10 00 11 Beginning Balance	1,226,482.54	1,226,482.54	0.00	100.0%
308 Beginning Balances	1,226,482.54	1,226,482.54	0.00	100.0%

310 Taxes

311 10 00 10 Property Tax	750,000.00	426,767.14	323,232.86	56.9%
310 Taxes	750,000.00	426,767.14	323,232.86	56.9%

330 Intergovernmental Revenues

332 93 40 10 GEMT	0.00	54,115.53	(54,115.53)	0.0%
330 Intergovernmental Revenues	0.00	54,115.53	(54,115.53)	0.0%

340 Charges For Services

342 60 01 10 Ambulance Service	200,000.00	142,080.99	57,919.01	71.0%
340 Charges For Services	200,000.00	142,080.99	57,919.01	71.0%

360 Investment Interest

361 11 00 11 Investment Interest	12,000.00	11,838.65	161.35	98.7%
360 Investment Interest	12,000.00	11,838.65	161.35	98.7%

Fund Revenues:	2,188,482.54	1,861,284.85	327,197.69	85.0%
-----------------------	---------------------	---------------------	-------------------	--------------

	Amt Budgeted	Expenditures	Remaining	
--	--------------	--------------	-----------	--

522 Fire Control

522 20 50 01 Ambulance Transport - Richland	0.00	0.00	0.00	0.0%
522 70 35 10 Small Tools And Minor Equipment	0.00	2,222.00	(2,222.00)	0.0%
522 70 41 00 Ambulance Billing Service Fee	18,000.00	8,629.85	9,370.15	47.9%
522 70 41 01 IMAGE TREND	0.00	0.00	0.00	0.0%
522 70 41 20 Ambulance Over Payment	0.00	1,976.49	(1,976.49)	0.0%
522 70 49 00 Other Expenditures	0.00	101,518.92	(101,518.92)	0.0%
522 Fire Control	18,000.00	114,347.26	(96,347.26)	635.3%

588 Prior Period Adjustment

588 10 00 10 PY Adjustments	0.00	0.00	0.00	0.0%
588 Prior Period Adjustment	0.00	0.00	0.00	0.0%

594 Capital Expenditures

594 22 63 10 Capital Apparatus	0.00	46,328.76	(46,328.76)	0.0%
594 Capital Expenditures	0.00	46,328.76	(46,328.76)	0.0%

2019 BUDGET POSITION

BENTON COUNTY FIRE PROTECTION L
 MCAG #: 1040

Time: 15:35:54 Date: 07/17/2019
 Page: 10

110 EMS Fund 01/01/2019 To: 12/31/2019

Expenditures	Amt Budgeted	Expenditures	Remaining	
597 Interfund Transfers				
597 00 01 10 Transfer Out To 001	857,884.00	0.00	857,884.00	0.0%
597 Interfund Transfers	857,884.00	0.00	857,884.00	0.0%
Fund Expenditures:	875,884.00	160,676.02	715,207.98	18.3%
Fund Excess/(Deficit):	1,312,598.54	1,700,608.83		

2019 BUDGET POSITION

BENTON COUNTY FIRE PROTECTION L
MCAG #: 1040

Time: 15:35:54 Date: 07/17/2019
Page: 11

201 EMS Bond Fund 01/01/2019 To: 12/31/2019

	Amt Budgeted	Revenues	Remaining	
--	--------------	----------	-----------	--

308 Beginning Balances

308 10 00 21 Beginning Balance	16,422.16	16,422.16	0.00	100.0%
308 Beginning Balances	16,422.16	16,422.16	0.00	100.0%

310 Taxes

311 10 00 21 Property Tax	0.00	314.37	(314.37)	0.0%
310 Taxes	0.00	314.37	(314.37)	0.0%

360 Investment Interest

361 11 00 21 Investment Interest	0.00	148.31	(148.31)	0.0%
360 Investment Interest	0.00	148.31	(148.31)	0.0%

380 Non Revenues

388 80 00 02 Prior Year(s) Corrections	0.00	0.00	0.00	0.0%
380 Non Revenues	0.00	0.00	0.00	0.0%

Fund Revenues:	16,422.16	16,884.84	(462.68)	102.8%
-----------------------	------------------	------------------	-----------------	---------------

	Amt Budgeted	Expenditures	Remaining	
--	--------------	--------------	-----------	--

591 Debt Service

591 22 71 01 Bond Principal Payment	0.00	0.00	0.00	0.0%
592 22 83 01 Bond Interest Payment	0.00	0.00	0.00	0.0%
592 22 89 21 Debt Service Cost	0.00	0.00	0.00	0.0%
591 Debt Service	0.00	0.00	0.00	0.0%

Fund Expenditures:	0.00	0.00	0.00	0.0%
---------------------------	-------------	-------------	-------------	-------------

Fund Excess/(Deficit):	16,422.16	16,884.84		
-------------------------------	------------------	------------------	--	--

2019 BUDGET POSITION

BENTON COUNTY FIRE PROTECTION D
 MCAG #: 1040

Time: 15:35:54 Date: 07/17/2019
 Page: 12

202 Construction Bond Fund 01/01/2019 To: 12/31/2019

	Amt Budgeted	Revenues	Remaining	
--	--------------	----------	-----------	--

308 Beginning Balances

308 10 00 22 Beginning Balance	0.00	0.00	0.00	0.0%
308 Beginning Balances	0.00	0.00	0.00	0.0%

310 Taxes

311 10 00 22 Property Tax	420,000.00	226,477.33	193,522.67	53.9%
311 11 02 02 Interest	0.00	0.00	0.00	0.0%
310 Taxes	420,000.00	226,477.33	193,522.67	53.9%

360 Investment Interest

361 11 00 22 Investment Interest	0.00	226.49	(226.49)	0.0%
360 Investment Interest	0.00	226.49	(226.49)	0.0%

380 Non Revenues

388 80 00 03 Prior Year(s) Corrections	0.00	0.00	0.00	0.0%
380 Non Revenues	0.00	0.00	0.00	0.0%

Fund Revenues:	420,000.00	226,703.82	193,296.18	54.0%
-----------------------	-------------------	-------------------	-------------------	--------------

	Amt Budgeted	Expenditures	Remaining	
--	--------------	--------------	-----------	--

591 Debt Service

591 22 71 00 Bond Principal Payment	100,000.00	0.00	100,000.00	0.0%
592 22 83 00 Bond Interest Payment	281,038.00	0.00	281,038.00	0.0%
591 Debt Service	381,038.00	0.00	381,038.00	0.0%

597 Interfund Transfers

597 00 00 21 Transfers-Out	0.00	0.00	0.00	0.0%
597 Interfund Transfers	0.00	0.00	0.00	0.0%

Fund Expenditures:	381,038.00	0.00	381,038.00	0.0%
---------------------------	-------------------	-------------	-------------------	-------------

Fund Excess/(Deficit):	38,962.00	226,703.82		
-------------------------------	------------------	-------------------	--	--

2019 BUDGET POSITION

BENTON COUNTY FIRE PROTECTION D
 MCAG #: 1040

Time: 15:35:54 Date: 07/17/2019
 Page: 13

401 Construction Fund 01/01/2019 To: 12/31/2019

	Amt Budgeted	Revenues	Remaining	
--	--------------	----------	-----------	--

308 Beginning Balances

308 10 00 41 Beginning Balance	7,629,850.00	7,585,638.31	44,211.69	99.4%
308 Beginning Balances	7,629,850.00	7,585,638.31	44,211.69	99.4%

360 Investment Interest

361 11 00 41 Investment Interest	1,000.00	66,673.67	(65,673.67)	6667.4%
360 Investment Interest	1,000.00	66,673.67	(65,673.67)	6667.4%

380 Non Revenues

388 80 00 04 Prior Year(s) Corrections	0.00	0.00	0.00	0.0%
380 Non Revenues	0.00	0.00	0.00	0.0%

390 Other Revenues

391 10 00 01 Bond Proceeds	0.00	0.00	0.00	0.0%
390 Other Revenues	0.00	0.00	0.00	0.0%

Fund Revenues:	7,630,850.00	7,652,311.98	(21,461.98)	100.3%
-----------------------	---------------------	---------------------	--------------------	---------------

	Amt Budgeted	Expenditures	Remaining	
--	--------------	--------------	-----------	--

591 Debt Service

592 22 89 00 Bond Fees	0.00	0.00	0.00	0.0%
591 Debt Service	0.00	0.00	0.00	0.0%

594 Capital Expenditures

594 22 62 01 Building Upgrade	803,048.00	92,292.44	710,755.56	11.5%
594 22 62 04 Capital Apparatus	0.00	206,122.80	(206,122.80)	0.0%
594 Capital Expenditures	803,048.00	298,415.24	504,632.76	37.2%

597 Interfund Transfers

597 00 01 01 Transfer Out	0.00	0.00	0.00	0.0%
597 Interfund Transfers	0.00	0.00	0.00	0.0%

Fund Expenditures:	803,048.00	298,415.24	504,632.76	37.2%
---------------------------	-------------------	-------------------	-------------------	--------------

Fund Excess/(Deficit):	6,827,802.00	7,353,896.74		
-------------------------------	---------------------	---------------------	--	--

2019 BUDGET POSITION

BENTON COUNTY FIRE PROTECTION C
 MCAG #: 1040

Time: 15:35:54 Date: 07/17/2019
 Page: 14

501 Equipment Fund 01/01/2019 To: 12/31/2019

	Amt Budgeted	Revenues	Remaining	
--	--------------	----------	-----------	--

308 Beginning Balances

308 80 00 51 Beginning Balance	443,081.60	443,081.60	0.00	100.0%
308 Beginning Balances	443,081.60	443,081.60	0.00	100.0%

310 Taxes

311 10 00 51 Property Tax	0.00	0.00	0.00	0.0%
310 Taxes	0.00	0.00	0.00	0.0%

360 Investment Interest

361 11 00 51 Investment Interest	0.00	3,974.01	(3,974.01)	0.0%
360 Investment Interest	0.00	3,974.01	(3,974.01)	0.0%

380 Non Revenues

388 80 00 05 Prior Year(s) Corrections	0.00	0.00	0.00	0.0%
380 Non Revenues	0.00	0.00	0.00	0.0%

390 Other Revenues

395 10 00 01 Sale Of Fixed Asset	0.00	0.00	0.00	0.0%
390 Other Revenues	0.00	0.00	0.00	0.0%

397 Interfund Transfers

397 00 00 05 Transfer In From 001	0.00	0.00	0.00	0.0%
397 Interfund Transfers	0.00	0.00	0.00	0.0%

Fund Revenues:	443,081.60	447,055.61	(3,974.01)	100.9%
-----------------------	-------------------	-------------------	-------------------	---------------

	Amt Budgeted	Expenditures	Remaining	
--	--------------	--------------	-----------	--

522 Fire Control

522 50 35 51 Small Tools And Minor Equipment	0.00	0.00	0.00	0.0%
000	0.00	0.00	0.00	0.0%
522 21 35 80 SCBA BOTTLES	0.00	0.00	0.00	0.0%
021 Suppression	0.00	0.00	0.00	0.0%
522 Fire Control	0.00	0.00	0.00	0.0%

594 Capital Expenditures

594 22 63 51 Capital Apparatus	0.00	0.00	0.00	0.0%
594 Capital Expenditures	0.00	0.00	0.00	0.0%

2019 BUDGET POSITION

BENTON COUNTY FIRE PROTECTION D
 MCAG #: 1040

Time: 15:35:54 Date: 07/17/2019

Page: 15

501 Equipment Fund 01/01/2019 To: 12/31/2019

Expenditures	Amt Budgeted	Expenditures	Remaining	
597 Interfund Transfers				
597 00 05 01 Transfer Out To 101	0.00	0.00	0.00	0.0%
597 Interfund Transfers	0.00	0.00	0.00	0.0%
Fund Expenditures:	0.00	0.00	0.00	0.0%
Fund Excess/(Deficit):	443,081.60	447,055.61		

2019 BUDGET POSITION

BENTON COUNTY FIRE PROTECTION D
 MCAG #: 1040

Time: 15:35:54 Date: 07/17/2019
 Page: 16

601 Reserve Fund 01/01/2019 To: 12/31/2019

	Amt Budgeted	Revenues	Remaining	
--	--------------	----------	-----------	--

308 Beginning Balances

308 80 00 61 Beginning Balance	636,871.30	636,871.30	0.00	100.0%
308 Beginning Balances	636,871.30	636,871.30	0.00	100.0%

360 Investment Interest

361 11 00 61 Investment Interest	0.00	5,738.67	(5,738.67)	0.0%
360 Investment Interest	0.00	5,738.67	(5,738.67)	0.0%

380 Non Revenues

388 80 00 06 Prior Year(s) Corrections	0.00	0.00	0.00	0.0%
380 Non Revenues	0.00	0.00	0.00	0.0%

397 Interfund Transfers

397 00 01 61 Transfer In From 101	48,584.00	48,584.00	0.00	100.0%
397 Interfund Transfers	48,584.00	48,584.00	0.00	100.0%

Fund Revenues:	685,455.30	691,193.97	(5,738.67)	100.8%
-----------------------	-------------------	-------------------	-------------------	---------------

	Amt Budgeted	Expenditures	Remaining	
--	--------------	--------------	-----------	--

597 Interfund Transfers

597 00 00 06 Transfer Out	0.00	0.00	0.00	0.0%
597 Interfund Transfers	0.00	0.00	0.00	0.0%

Fund Expenditures:	0.00	0.00	0.00	0.0%
---------------------------	-------------	-------------	-------------	-------------

Fund Excess/(Deficit):	685,455.30	691,193.97		
-------------------------------	-------------------	-------------------	--	--

2019 BUDGET POSITION TOTALS

BENTON COUNTY FIRE PROTECTIO
 MCAG #: 1040

Time: 15:35:54 Date: 07/17/2019

Page: 17

Fund	Revenue Budgeted	Received		Expense Budgeted	Spent	
001 General Fund	5,023,774.42	3,077,119.28	61.3%	3,790,284.18	2,228,127.99	59%
004 Health Reimbursement Fund	83.10	83.70	100.7%	0.00	0.00	0%
007 Separation Fund	60,087.24	60,205.20	100.2%	0.00	0.00	0%
110 EMS Fund	2,188,482.54	1,861,284.85	85.0%	875,884.00	160,676.02	18%
201 EMS Bond Fund	16,422.16	16,884.84	102.8%	0.00	0.00	0%
202 Construction Bond Fund	420,000.00	226,703.82	54.0%	381,038.00	0.00	0%
401 Construction Fund	7,630,850.00	7,652,311.98	100.3%	803,048.00	298,415.24	37%
501 Equipment Fund	443,081.60	447,055.61	100.9%	0.00	0.00	0%
601 Reserve Fund	685,455.30	691,193.97	100.8%	0.00	0.00	0%
	<u>16,468,236.36</u>	<u>14,032,843.25</u>	85.2%	<u>5,850,254.18</u>	<u>2,687,219.25</u>	45.9%

WARRANT/CHECK REGISTER

BENTON COUNTY FIRE PROTECTION DISTRI

Time: 15:13:13 Date: 07/17/2019

MCAG #: 1040

07/26/2019 To: 07/26/2019

Page: 1

Trans	Date	Type	Acct #	War #	Claimant	Amount	Memo
861	07/26/2019	Claims	1	185129	ABV	100.00	BALANCE OWED
862	07/26/2019	Payroll	1	185130	AFLAC	180.28	Pay Cycle(s) 04/01/2019 To 04/30/2019 - AFLAC
863	07/26/2019	Claims	1	185131	AMERIGAS	179.19	STA420 PROPANE TANK RENTAL
864	07/26/2019	Claims	1	185132	AMERIGAS	179.19	STA410 PROPANE TANK RENTAL
865	07/26/2019	Payroll	1	185133	BENTON COUNTY 4 BENEVOLENT FUND	46.00	Pay Cycle(s) 04/01/2019 To 04/30/2019 - Benevolent Fund
866	07/26/2019	Claims	1	185134	BPAS	4,000.00	HRA
867	07/26/2019	Claims	1	185135	BRADLEY, SLITA	1,177.72	TUITION REIMBURSEMENT; MILEAGE TO POWERLINE FIRE
868	07/26/2019	Claims	1	185136	CI SHRED	36.09	DOCUMENT STORAGE
869	07/26/2019	Claims	1	185137	CI SHRED	34.35	SHREDDING SERVICE
870	07/26/2019	Claims	1	185138	CORWIN FORD	16,558.94	APP MAINT
871	07/26/2019	Payroll	1	185139	DIMARTINO	908.34	Pay Cycle(s) 04/01/2019 To 04/30/2019 - LT Disab- Life
872	07/26/2019	Claims	1	185140	FIRE 4 CHECKING ACCOUNT	1,224.34	MISC EXPENSES
873	07/26/2019	Claims	1	185141	FRONTIER	162.50	DEDICATED LINES
874	07/26/2019	Claims	1	185142	HARRINGTON'S TROPHIES	166.00	TOOLS
875	07/26/2019	Claims	1	185143	HOME DEPOT	344.62	FACILITY SUPPLIES
876	07/26/2019	Payroll	1	185144	IAFF LOCAL 1052	1,714.02	Pay Cycle(s) 04/01/2019 To 04/30/2019 - Union Dues
877	07/26/2019	Claims	1	185145	LIBERTY LAWN CARE	124.64	STATION SUPPLIES
878	07/26/2019	Claims	1	185146	LIFE ASSIST	1,437.65	MISC EMS SUPPLIES
879	07/26/2019	Claims	1	185147	MCGAVICK GRAVES ATTORNEY AT LAW	216.00	LEGAL SERVICE
880	07/26/2019	Claims	1	185148	NEWEGG	1,669.35	COMPUTER PARTS
881	07/26/2019	Claims	1	185149	NORTHWEST SAFETY CLEAN	114.65	PPE CLEANING
882	07/26/2019	Claims	1	185150	O'REILLY AUTO PARTS	109.37	APP SUPPLIES
883	07/26/2019	Claims	1	185151	OXARC	44.21	O2
884	07/26/2019	Claims	1	185152	RICHLAND, CITY OF	5,280.50	DISPATCH SERVICE
885	07/26/2019	Claims	1	185153	SAFETY AND TECHNICAL RESCUE ASSOCIATION	5,000.00	RESCUE TRAINING(5)
886	07/26/2019	Claims	1	185154	STEEBER'S LOCK SERVICE	9.29	DUPLICATE KEYS
887	07/26/2019	Claims	1	185155	STERICYCLE	99.03	WMS WASTE PICKUP
888	07/26/2019	Payroll	1	185156	TRUSTEED PLANS SERVICE CORPORATION	24,537.01	Pay Cycle(s) 04/01/2019 To 04/30/2019 - Medical Insurance; Pay Cycle(s) 04/01/2019 To 04/30/2019 - Dental Insurance
889	07/26/2019	Claims	1	185157	US BANK	2,638.04	VISA- BENITZ; VISA- SHANNON; VISA- CARLYLE; VISA- NEWTON; VISA- NEWTON; VISA- WHEALAN; VISA- BRADLEY
890	07/26/2019	Payroll	1	185158	WA PUB EMP & RETIRE SYS	26,869.98	Pay Cycle(s) 04/01/2019 To 04/30/2019 - LEOFF II; Pay Cycle(s) 04/01/2019 To 04/30/2019 - Deferred Comp; Pay Cycle(s) 04/01/2019 To 04/30/2019 - PERS 3
891	07/26/2019	Payroll	1	185159	C/O BENEFIT SOLUTIONS INC WSCFF MEDICAL EXPENSE REIMBURSEMEN	1,050.00	Pay Cycle(s) 04/01/2019 To 04/30/2019 - MERP
892	07/26/2019	Claims	1	185160	YOKE'S FOODS	64.74	LOGISTICS SUPPLIES
824	07/26/2019	Payroll	1	1039156	REX J GREEN	254.65	Jun Pay FLSA 05/06-06/30
829	07/26/2019	Payroll	1	1039157	JOSEPH W MEHLINE	277.05	Jun Pay FLSA 05/06-06/30
830	07/26/2019	Payroll	1	1039158	JONATHAN SCHWARDER	277.05	Jun Pay FLSA 05/06-06/30
860	07/26/2019	Claims	401	5556	STRATTON SURVEYING	455.00	SURVEY

WARRANT/CHECK REGISTER

BENTON COUNTY FIRE PROTECTION DISTRICT

Time: 15:13:13 Date: 07/17/2019

MCAG #: 1040

07/26/2019 To: 07/26/2019

Page: 2

Trans	Date	Type	Acct #	War #	Claimant	Amount	Memo
			522		Fire Control	73,638.69	
			589		Payroll Clearing	23,446.10	
		001	General Fund			97,084.79	
			594		Capital Expenditures	455.00	
		401	Construction Fund			455.00	
						Claims:	41,425.41
						97,539.79 Payroll:	56,114.38

We, the undersigned, do hereby certify that the materials have been furnished, the services rendered or the labor performed as described herein and that the claim is a just, due and unpaid obligation against Benton County Fire District #4, and that we are authorized to authenticate and certify to said claim.

Admin Staff _____ Secretary *[Signature]*
Commissioners *[Signature]*, *[Signature]*, *[Signature]*
Approval Date *[Signature]* 07/18/19

WARRANT/CHECK REGISTER

BENTON COUNTY FIRE PROTECTION DISTRICT

Time: 15:13:41 Date: 07/17/2019

MCAG #: 1040

07/26/2019 To: 07/26/2019

Page: 1

Trans	Date	Type	Acct #	War #	Claimant	Amount	Memo
820	07/26/2019	Payroll	1	EFT	JOHN THOMAS CLARY	277.05	Jun Pay FLSA 05/06-06/30
821	07/26/2019	Payroll	1	EFT	MARTIN FITZHUGH	454.37	Jun Pay FLSA 05/06-06/30
822	07/26/2019	Payroll	1	EFT	GARRETT S GOODWIN	208.48	Jun Pay FLSA 05/06-06/30
823	07/26/2019	Payroll	1	EFT	AMIE GREEN	137.38	Jun Pay FLSA 05/06-06/30
825	07/26/2019	Payroll	1	EFT	JACOB GUTTROMSON	204.94	Jun Pay FLSA 05/06-06/30
826	07/26/2019	Payroll	1	EFT	KYLE J JAGELSKI	725.95	Jun Pay FLSA 05/06-06/30
827	07/26/2019	Payroll	1	EFT	PATRICIA KIRKHAM	554.10	Jun Pay FLSA 05/06-06/30
828	07/26/2019	Payroll	1	EFT	JONATHAN LUCAS	182.47	Jun Pay FLSA 05/06-06/30
831	07/26/2019	Payroll	1	EFT	LUCAS SIMMONS	163.46	Jun Pay FLSA 05/06-06/30
832	07/26/2019	Payroll	1	EFT	CAROLINE SMITH	163.92	Jun Pay FLSA 05/06-06/30
833	07/26/2019	Payroll	1	EFT	CHRISTOPHER YAROCH	171.77	Jun Pay FLSA 05/06-06/30
834	07/26/2019	Payroll	1	EFT	BONNIE M BENITZ	7,571.28	Jun Pay FLSA 05/06-06/30
835	07/26/2019	Payroll	1	EFT	MATTHEW J BORSCHOWA	5,527.07	Jun Pay FLSA 05/06-06/30
836	07/26/2019	Payroll	1	EFT	SLITA T BRADLEY	4,486.50	Jun Pay FLSA 05/06-06/30
837	07/26/2019	Payroll	1	EFT	PAUL E CARLYLE	7,073.85	Jun Pay FLSA 05/06-06/30
838	07/26/2019	Payroll	1	EFT	GREGG COUCH	353.65	Jun Pay FLSA 05/06-06/30
839	07/26/2019	Payroll	1	EFT	KEVIN G GAIDOS	4,702.26	Jun Pay FLSA 05/06-06/30
840	07/26/2019	Payroll	1	EFT	THOMAS R HARPER	4,601.38	Jun Pay FLSA 05/06-06/30
841	07/26/2019	Payroll	1	EFT	ANDREW J HILL	586.42	Jun Pay FLSA 05/06-06/30
842	07/26/2019	Payroll	1	EFT	BRAYDON JAMES JOHNSON	835.85	Jun Pay FLSA 05/06-06/30
843	07/26/2019	Payroll	1	EFT	JAMES A LONGIE	4,162.33	Jun Pay FLSA 05/06-06/30
844	07/26/2019	Payroll	1	EFT	JULIAN LORRAINE	870.84	Jun Pay FLSA 05/06-06/30
845	07/26/2019	Payroll	1	EFT	AARON J MELOY	5,039.31	Jun Pay FLSA 05/06-06/30
846	07/26/2019	Payroll	1	EFT	SAMUAL S MONDS	1,145.84	Jun Pay FLSA 05/06-06/30
847	07/26/2019	Payroll	1	EFT	RAYMOND J NEWTON	5,775.15	Jun Pay FLSA 05/06-06/30
848	07/26/2019	Payroll	1	EFT	GARRETT M PREMEL	5,239.14	Jun Pay FLSA 05/06-06/30
849	07/26/2019	Payroll	1	EFT	ALLEN LEE PUTZ	4,633.29	Jun Pay FLSA 05/06-06/30
850	07/26/2019	Payroll	1	EFT	KYLE M RICHE	725.49	Jun Pay FLSA 05/06-06/30
851	07/26/2019	Payroll	1	EFT	RALPH WOODY RUSSELL	468.54	Jun Pay FLSA 05/06-06/30
852	07/26/2019	Payroll	1	EFT	ROBERT C SHANNON	6,730.16	Jun Pay FLSA 05/06-06/30
853	07/26/2019	Payroll	1	EFT	RYAN P SOMMERVILLE	559.57	Jun Pay FLSA 05/06-06/30
854	07/26/2019	Payroll	1	EFT	JACK L VAN HOORELBEKE	249.34	Jun Pay FLSA 05/06-06/30
855	07/26/2019	Payroll	1	EFT	ANTHONY G VINING	5,219.74	Jun Pay FLSA 05/06-06/30
856	07/26/2019	Payroll	1	EFT	WILLIAM H WHEALAN JR	6,691.39	Jun Pay FLSA 05/06-06/30
857	07/26/2019	Payroll	1	EFT	DAVID G WINN	4,576.72	Jun Pay FLSA 05/06-06/30
858	07/26/2019	Payroll	1	EFT	CODY WINTERS	4,693.02	Jun Pay FLSA 05/06-06/30

522 Fire Control	137,824.04
589 Payroll Clearing	-42,062.02
001 General Fund	95,762.02

95,762.02 Payroll: 95,762.02

We, the undersigned, do hereby certify that the materials have been furnished, the services rendered or the labor performed as described herein and that the claim is a just, due and unpaid obligation against Benton County Fire District #4, and that we are authorized to authenticate and certify to said claim.

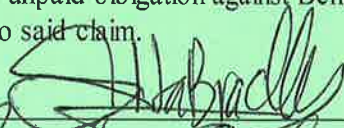
Admin Staff _____ Secretary 

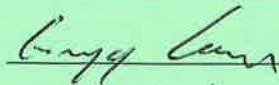
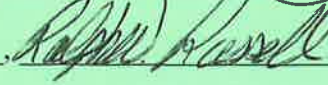
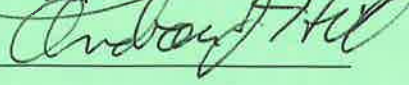
Commissioners   

Approval Date 07/18/19

WARRANT/CHECK REGISTER

BENTON COUNTY FIRE PROTECTION DISTRICT

Time: 15:14:27 Date: 07/17/2019

MCAG #: 1040

07/25/2019 To: 07/25/2019

Page: 1

Trans	Date	Type	Acct #	War #	Claimant	Amount	Memo
859	07/25/2019	Payroll	1	185128	EFTPS- IRS Payroll Taxes	21,701.48	941 Deposit for Pay Cycle(s) 07/26/2019 - 07/26/2019
			522 Fire Control			3,136.95	
			589 Payroll Clearing			18,564.53	
			001 General Fund			21,701.48	
						21,701.48	Payroll: 21,701.48

We, the undersigned, do hereby certify that the materials have been furnished, the services rendered or the labor performed as described herein and that the claim is a just, due and unpaid obligation against Benton County Fire District #4, and that we are authorized to authenticate and certify to said claim.

Admin Staff _____ Secretary *[Signature]*
Commissioners *[Signature]* *[Signature]* *[Signature]*
Approval Date 07/18/19

ACCOUNTS PAYABLE PAID

BENTON COUNTY FIRE PROTECTION DISTRICT
 MCAG #: 1040

Time: 15:37:46 Date: 07/17/2019
 Page: 1

07/26/2019 To: 07/26/2019

Accts Pay #	Paid On	Year	Trans	Vendor ID	Vendor	Amount	Memo
9368	07/26/2019	2019	861	724	ABV	100.00	BALANCE OWED
	522 50 48 00	Repair & Maint. - Facilities	001 000 522	General Fund		100.00	BALANCE OWED
<hr/>							
9369	07/26/2019	2019	863	828	AMERIGAS	179.19	STA420 PROPANE TANK RENTAL
	522 50 48 00	Repair & Maint. - Facilities	001 000 522	General Fund		179.19	STA420 PROPANE TANK RENTAL
<hr/>							
9370	07/26/2019	2019	864	828	AMERIGAS	179.19	STA410 PROPANE TANK RENTAL
	522 50 48 00	Repair & Maint. - Facilities	001 000 522	General Fund		179.19	STA410 PROPANE TANK RENTAL
<hr/>							
9371	07/26/2019	2019	866	690	BPAS	4,000.00	HRA
	522 12 20 04	HRA Benefits	001 000 522	General Fund		500.00	HRA
	522 21 20 04	HRA Benefits	001 000 522	General Fund		3,500.00	HRA
<hr/>							
9372	07/26/2019	2019	867	496	BRADLEY, SLITA	1,100.00	TUITION REIMBURSEMENT
	522 45 43 30	Tuition Reimbursement	001 000 522	General Fund		1,100.00	TUITION REIMBURSEMENT
<hr/>							
9373	07/26/2019	2019	867	496	BRADLEY, SLITA	77.72	MILEAGE TO POWERLINE FIRE
	522 60 32 00	Fuels	001 000 522	General Fund		77.72	MILEAGE TO POWERLINE FIRE
<hr/>							
						77.72	MILEAGE TO POWERLINE FIRE

ACCOUNTS PAYABLE PAID

BENTON COUNTY FIRE PROTECTION DISTRICT
 MCAG #: 1040

Time: 15:37:46 Date: 07/17/2019
 Page: 2

07/26/2019 To: 07/26/2019

Accts Pay #	Paid On	Year	Trans	Vendor ID	Vendor	Amount	Memo
9374	07/26/2019	2019	868	628	CI SHRED	36.09	DOCUMENT STORAGE
	522 12 41 00	Contract Services			001 000 522 General Fund	36.09	DOCUMENT STORAGE
<hr/>							
					Invoice		
					0084278	36.09	DOCUMENT STORAGE
9375	07/26/2019	2019	869	628	CI SHRED	34.35	SHREDDING SERVICE
	522 12 41 00	Contract Services			001 000 522 General Fund	34.35	SHREDDING SERVICE
<hr/>							
					Invoice		
					0084870	34.35	SHREDDING SERVICE
9376	07/26/2019	2019	870	840	CORWIN FORD	16,558.94	APP MAINT
	522 60 48 00	Repair & Maint. - Automotive			001 000 522 General Fund	16,558.94	APP MAINT
<hr/>							
					Invoice		
					694588	16,105.41	APP19
					697756	337.93	APP33
					697323	115.60	APP35
9377	07/26/2019	2019	872	704	FIRE 4 CHECKING ACCOUNT	1,224.34	MISC EXPENSES
	522 12 31 00	Expendable Office Supplies			001 000 522 General Fund	46.70	BUSINESS CHECKS
	522 12 45 00	Equipment Lease/Maint			001 000 522 General Fund	122.73	COPY MAHINE 410
	522 50 47 10	Electricity			001 000 522 General Fund	506.14	STA420
	522 50 47 10	Electricity			001 000 522 General Fund	38.48	WELLHOUSE
	522 50 47 10	Electricity			001 000 522 General Fund	189.32	SHOP
	522 50 47 10	Electricity			001 000 522 General Fund	320.97	STA410
<hr/>							
					Invoice		
					1195	122.73	
					07052019	46.70	
					1194	1,054.91	
9378	07/26/2019	2019	873	357	FRONTIER	162.50	DEDICATED LINES
	522 12 42 00	Phone Service			001 000 522 General Fund	162.50	DEDICATED LINES

ACCOUNTS PAYABLE PAID

BENTON COUNTY FIRE PROTECTION DISTRICT
 MCAG #: 1040

Time: 15:37:46 Date: 07/17/2019
 Page: 3

07/26/2019 To: 07/26/2019

Accts Pay #	Paid On	Year	Trans	Vendor ID	Vendor	Amount	Memo
<u>Invoice</u>							
	08052019					162.50	DEDICATED LINES
9379	07/26/2019	2019	874	152	HARRINGTON'S TROPHIES	166.00	TOOLS
	522 60 35 00	Tools & Equipment - Automoti	001 000 522	General Fund		166.00	TOOLS
<u>Invoice</u>							
	888213					166.00	TOOLS
9380	07/26/2019	2019	875	831	HOME DEPOT	344.62	FACILITY SUPPLIES
	522 50 31 00	Expendable Supplies - Facilities	001 000 522	General Fund		133.48	WEED KILLER
	522 50 35 00	Tools & Equipment - Facilities	001 000 522	General Fund		211.14	PAINTING SUPPLIES
<u>Invoice</u>							
	7590236					133.48	
	1591741					211.14	
9381	07/26/2019	2019	877	757	LIBERTY LAWN CARE	124.64	STATION SUPPLIES
	522 50 35 00	Tools & Equipment - Facilities	001 000 522	General Fund		124.64	STATION SUPPLIES
<u>Invoice</u>							
	6206					124.64	STATION SUPPLIES
9382	07/26/2019	2019	878	187	LIFE ASSIST	1,437.65	MISC EMS SUPPLIES
	522 70 31 00	Expendable Supplies - EMS	001 000 522	General Fund		1,437.65	MISC EMS SUPPLIES
<u>Invoice</u>							
	929710					150.76	
	929335					726.43	
	931566					560.46	
9383	07/26/2019	2019	879	779	MCGAVICK GRAVES ATORNEY A	216.00	LEGAL SERVICE
	522 14 41 00	Legal Services	001 000 522	General Fund		216.00	LEGAL SERVICE
<u>Invoice</u>							
	06302019					216.00	LEGAL SERVICE

ACCOUNTS PAYABLE PAID

BENTON COUNTY FIRE PROTECTION DISTRIC
 MCAG #: 1040

Time: 15:37:46 Date: 07/17/2019
 Page: 4

07/26/2019 To: 07/26/2019

Accts Pay #	Paid On	Year	Trans	Vendor ID	Vendor	Amount	Memo
9384	07/26/2019	2019	880	860	NEWEGG	1,669.35	COMPUTER PARTS
	522 12 35 10	Office Computer Equipment		001 000 522	General Fund	1,669.35	COMPUTER PARTS
Invoice							
						651.53	
						32.57	
						206.33	
						743.09	
						35.83	
9385	07/26/2019	2019	881	237	NORTHWEST SAFETY CLEAN	114.65	PPE CLEANING
	522 21 41 00	Professional Services		001 000 522	General Fund	114.65	PPE CLEANING
Invoice							
						114.65	PPE CLEANING
9386	07/26/2019	2019	882	535	O'REILLY AUTO PARTS	109.37	APP SUPPLIES
	522 60 31 00	Expendable Supplies - Automo		001 000 522	General Fund	109.37	APP SUPPLIES
Invoice							
						109.37	APP SUPPLIES
9387	07/26/2019	2019	883	242	OXARC	44.21	O2
	522 70 31 00	Expendable Supplies - EMS		001 000 522	General Fund	44.21	O2
Invoice							
						44.21	O2
9388	07/26/2019	2019	884	281	RICHLAND, CITY OF	5,280.50	DISPATCH SERVICE
	522 24 41 00	Dispatch Services		001 000 522	General Fund	5,280.50	DISPATCH SERVICE
Invoice							
						5,280.50	DISPATCH SERVICE
9389	07/26/2019	2019	885	865	SAFETY AND TECHNICAL RESCU	5,000.00	RESCUE TRAINING(5)

ACCOUNTS PAYABLE PAID

BENTON COUNTY FIRE PROTECTION DISTRICT
 MCAG #: 1040

Time: 15:37:46 Date: 07/17/2019
 Page: 5

07/26/2019 To: 07/26/2019

Accts Pay #	Paid On	Year	Trans	Vendor ID	Vendor	Amount	Memo
	522 45 43 20		Registration Fees(Operations)	001 000 522	General Fund	5,000.00	RESCUE TRAINING(S)
Invoice							
	2871					5,000.00	RESCUE TRAINING(S)
9390	07/26/2019	2019	886	325	STEEBER'S LOCK SERVICE	9.29	DUPLICATE KEYS
	522 50 35 00		Tools & Equipment - Facilities	001 000 522	General Fund	9.29	DUPLICATE KEYS
Invoice							
	579135					9.29	DUPLICATE KEYS
9392	07/26/2019	2019	887	625	STERICYCLE	99.03	WMS WASTE PICKUP
	522 70 41 10		Contract Services - EMS	001 000 522	General Fund	99.03	WMS WASTE PICKUP
Invoice							
	3004756263					99.03	WMS WASTE PICKUP
9391	07/26/2019	2019	860	328	STRATTON SURVEYING	455.00	SURVEY
	594 22 62 01		Building Upgrade	401 000 594	Construction Fund	455.00	SURVEY
Invoice							
	17407					455.00	SURVEY
9394	07/26/2019	2019	889	475	US BANK	72.24	VISA- BENITZ
	522 60 32 00		Fuels	001 000 522	General Fund	72.24	FUEL
Invoice							
	BENI1					72.24	4485594555563475
9395	07/26/2019	2019	889	475	US BANK	783.32	VISA- SHANNON
	522 21 31 10		Supplies - Support Service	001 000 522	General Fund	88.30	LOGISTICS SUPPLIES
	522 50 35 00		Tools & Equipment - Facilities	001 000 522	General Fund	695.02	TVS FOR VOLUNTEER ROOMS
Invoice							
	SHANI					783.32	4485594555563475
9396	07/26/2019	2019	889	475	US BANK	527.54	VISA- CARLYLE

ACCOUNTS PAYABLE PAID

BENTON COUNTY FIRE PROTECTION DISTRICT
 MCAG #: 1040

Time: 15:37:46 Date: 07/17/2019
 Page: 6

07/26/2019 To: 07/26/2019

Accts	Pay #	Paid On	Year	Trans	Vendor ID	Vendor	Amount	Memo
		522 12 35 00		Office Tools & Equipment	001 000 522	General Fund	162.89	PROJECTOR SCREEN
		522 21 31 10		Supplies - Support Service	001 000 522	General Fund	99.78	REFRESHMENT FIRE MOUNT FIRE
		522 21 31 10		Supplies - Support Service	001 000 522	General Fund	187.62	EVERETT FIRE REFRESHMENT
		522 60 48 00		Repair & Maint. - Automotive	001 000 522	General Fund	77.25	TIRE SWAP APP 34 AND 39
Invoice								
		CARLI					527.54	4485594555563475
9397	07/26/2019	2019	889	475	US BANK		39.09	VISA- NEWTON
		522 21 31 00		Expendable Supplies - Suppres	001 000 522	General Fund	39.09	BATTERIES
Invoice								
		NEWTI					39.09	4485594555563475
9398	07/26/2019	2019	889	475	US BANK		66.16	VISA- NEWTON
		522 21 35 10		Tools & Equipment -Suppressi	001 000 522	General Fund	22.77	SHACKIES
		522 24 31 00		Expendable Supplies - Radios	001 000 522	General Fund	43.39	MIC CLIP
Invoice								
		NEWTI					66.16	4485594555563475
9399	07/26/2019	2019	889	475	US BANK		25.50	VISA- WHEALAN
		522 12 42 40		Postage	001 000 522	General Fund	25.50	OVERNIGHT MAIL TO HUGHES
Invoice								
		WHEAI					25.50	4485594555563475
9400	07/26/2019	2019	889	475	US BANK		1,124.19	VISA- BRADLEY
		522 12 35 00		Office Tools & Equipment	001 000 522	General Fund	378.95	SIX SIGMA BOOK
		522 12 41 00		Contract Services	001 000 522	General Fund	499.56	OFFICE365
		522 12 41 00		Contract Services	001 000 522	General Fund	60.00	SPLASHTOP
		522 21 35 10		Tools & Equipment -Suppressi	001 000 522	General Fund	185.68	LOGISTICS TENTS
Invoice								
		BRADI					1,124.19	4485594555563475
9393	07/26/2019	2019	892	394	YOKE'S FOODS		64.74	LOGISTICS SUPPLIES

ACCOUNTS PAYABLE PAID

BENTON COUNTY FIRE PROTECTION DISTRICT
 MCAG #: 1040

Time: 15:37:46 Date: 07/17/2019
 Page: 7

07/26/2019 To: 07/26/2019

Accts Pay #	Paid On	Year	Trans	Vendor ID	Vendor	Amount	Memo
<hr/>							
522 21 31 10	Supplies - Support Service	001 000 522	General Fund	64.74	LOGISTICS SUPPLIES		
<hr/>							
Invoice							
91459						24.90	
91562						39.84	
						41,425.41	Total:
<hr/>							
Fund							
						40,970.41	001 General Fund
						455.00	401 Construction Fund

We, the undersigned, do hereby certify that the materials have been furnished, the services rendered or the labor performed as described herein and that the claim is a just, due and unpaid obligation against Benton County Fire District #4, and that we are authorized to authenticate and certify to said claim.



Benton County Fire Protection District No. 4

RESOLUTION NO. 2019-03

EQUIPMENT SURPLUS

WHEREAS, the Benton County Fire Protection District No.4 Commissioners have declared that the equipment on the Appendix A is no longer needed by the District;

NOW, THEREFORE, BE IT RESOLVED, that the Board of Fire Commissioners of Benton County Fire Protection District No.4, hereby excess the listed items.

ADOPTED at the regular meeting of the Board of Fire Commissioners of Benton County Fire Protection District No.4 on this 3RD day of July 2019, the following Commissioners being present and voting.

Chairperson

Commissioner

Commissioner

Attest:

District Secretary

Appendix A

2010 White Ford E450 Ambulance cut away chassis

BCFD#4 Inventory #29

VIN Number: 1FDXE4FS0ADA15250

Lic #96288C

Mileage: 67757.3

Please excess the following;

2010, Ford E450 Ambulance cut away chassis white in color

BCFD#4 Inventory #29

VIN Number: 1FDXE4FS0ADA15250

This is not an entire excess package. The ambulance box itself along with associated emergency components will be repurposed onto a new chassis.

Braun Northwest has agreed to a trade in value of \$500 for the chassis with cutaway cab.

Quotation

Customer:	Benton County Fire District	Ship To:	West Richland, WA
Attention:	Slita		
Phone #:	719-406-2772	Fx:	

Date: 7/18/2019	Terms: Upon Invoice	Ship Via: Common Carrier
Salesperson: Bill Ackerman	Quotation good for 30 days, subject to availability	

<u>Qty.</u>	<u>Description</u>	
1	8x28 mobile office	
1		
1		
1		
<u>Pricing</u>		
<u>Building Charges</u>	<u>Purchase Price</u>	<u>Lease Rate</u>
8x28 mobile office	\$36,500.00	\$350.00
Metal steps per set	\$650.00	\$10.00
ADA ramp	\$15,300.00	\$185.00
One Time Charges (Billed at start of Lease)		
Delivery:(pilots not included)	per unit	\$200.00
Setup: block & level		\$100.00
Tie downs: (if you need them)	per tie down	\$125.00
Skirting: (if you need them)	per lf skirting	\$25.00
One Time Charges (Billed at end of Lease)		
Return freight: (pilots not included)		\$200.00
Teardown: 24x60 mobile office		\$100.00
Tie down removal:		Included
Skirting removal:		Included
OPTIONS:		
ADA Ramp (pricing varies on length of lease and threshold height)		

- Sales Tax is not included in your quote above. Sales Tax (8.9%) is charged on all the materials and the monthly pricing including DOH fee's.
- DOH fee's and Sale Tax will be included on all invoices
- If buildings need to be rolled or nosed into place there will be additional costs.
- Please add \$105 for each additional tiedown; if required. If site is un-level or tires, axels & hitches need to
- Set-up cost based on 1,500 p.s.f. soil bearing capacity.
- Pricing is based upon others providing all permits, fees, taxes, licenses, utility connections and preparation

Benton County Fire District #4, 2604 Bombing Range Rd., West Richland, WA 99353



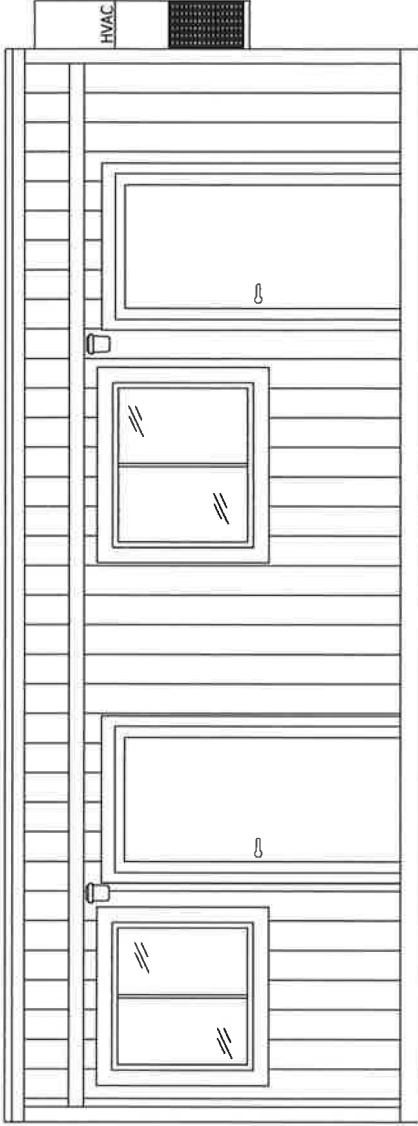
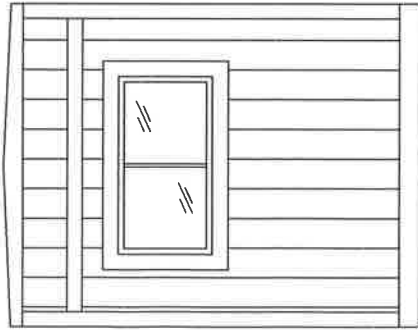

- 224 square feet of office space with one private office and a spacious open area with space for up to four people.
- Two integrated work stations with desktop and file cabinets as well as one plan table.
- Our buildings are completely insulated and come with a heating and air conditioning system for a comfortable work environment.
- Vinyl floors offer a near maintenance free office building.
- Upgraded interior wall coverings & decorative wood siding for a professional appearance.

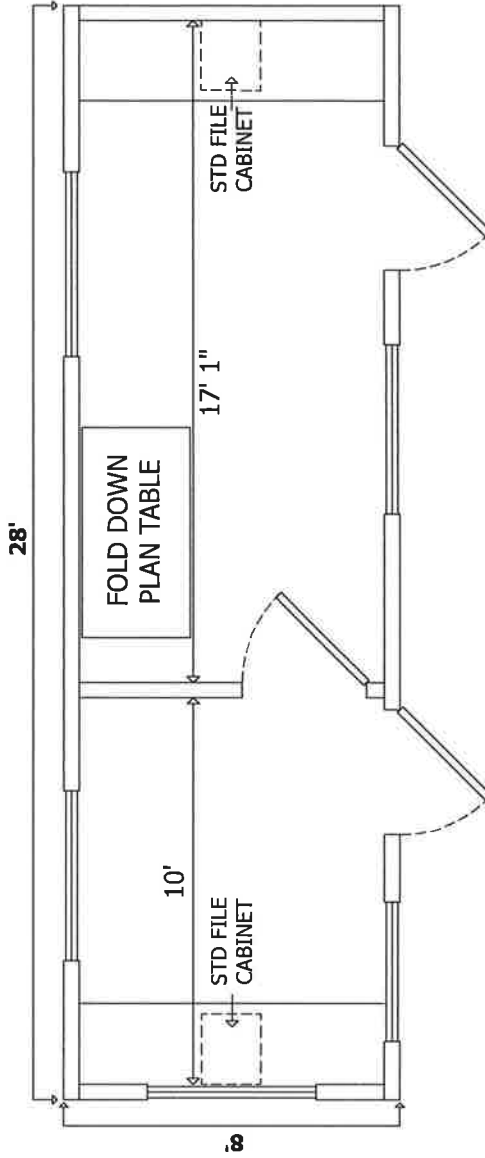

Note: Dimensions, and door & window locations shown are nominal. Actual dimensions, layout, and roof slope may vary depending on model or model year selected.

Your Local
Sales Professional
Bill Ackerman
509.375.4858

8' x 28' Mobile Office Building

Delivered ready to use "On Time and On Budget"



www.DesignSpaceModular.com

STRUCTURAL NOTES:

1. GENERAL:
 - 1.1. ALL DIMENSION OF UNIT COMPONENTS MAY VARY DEPENDING ON BUILDING MANUFACTURER. MINOR VARIATIONS DO NOT SIGNIFICANTLY CHANGE THE CHARACTERISTICS OF THE FOUNDATION DESIGN AND ARE ALLOWED.
 - 1.2. DESIGN AND DETAILING IS BASED ON THE MORE RESTRICTIVE CRITERIA FROM THE FOLLOWING BUILDING CODES:
 - 1.2.1. INTERNATIONAL BUILDING CODE, 2015 EDITION & SUPPLEMENTS
 - 1.2.2. OREGON STRUCTURAL SPECIALTY CODE, 2014 EDITION
2. DESIGN INFORMATION & LOADING:
 - 2.1. BUILDING RISK FACTOR II
 - 2.2. ROOF LIVE LOAD 40 PSF (SNOW), $Is = 1.0$, $Cf = 1.1$, $S = 50$ PSF OR 2,000# CONC. (OFFICE)
 - 2.3. FLOOR LIVE LOAD 50 PSF OR 2,000# CONC. (OFFICE)
 - 2.4. WIND CRITERION 110 MPH (Wind), EXP B/C, $Kz = 1.0$
 - 2.5. SEISMIC CRITERION $SDS = 1.0$, $Ie = 1.0$, CLASS 'D', CATEGORY 'D'
 - 2.6. ASSUMED SOIL BEARING 1,500 PSF (VERIFY W/LOCAL BUILDING OFFICIAL)
 - 2.7. WALL PLATE HEIGHT 9'-0"
 - 2.8. ROOF SLOPE 3:12 OR FLATTER
3. CONCRETE:
 - 3.1. DESIGN COMP. STRENGTH 2,500 PSI
 - 3.2. REIN. YIELD 60 KSI
4. MASONRY:
 - 4.1. 8X16X8 UNITS ASTM C-90, GRADE N
 - 4.2. SET UNITS W/CORES VERTICAL & NO MORE THAN 3 HIGH, PER PLAN, WITHOUT SOLID GROUTING CORES. SOLID GROUTED CORES WITH STACKS OVER 3 HIGH. ANY STACK OVER 5 HIGH REQUIRES SPECIFIC ENGINEERING.
5. SPECIALTY ITEMS: ("MINUTE MAN PRODUCTS, INC.", (800) 438-7277 www.minutemanproducts.com, OR EQUIVALENT)
 - 5.1. METAL PIERS TO BE CAPABLE OF SUPPORTING 6,000#
 - 5.2. LATERAL ANCHORS SHALL BE: DRIVEN ANCHOR W/ STABILIZER PLATE (36X & MMA-5D2A OR AZTEC ANCHOR); AUGER-TYPE SET VERTICAL W/STABILIZER FLATE OR HEAD/EZ4430 3/4" DI W/STABILIZER; W/ A MIN. ULTIMATE LOAD OF 4,725#. NUM/BR OF ANCHORS AS INDICATED ON TABLE A. CORNER TIE-DOWNS TO BE WITHIN 3'-0" OF THE BUILDING CORNER. TIE-DOWNS OTHER THAN AT THE CORNERS SHALL BE SPACED EQUALLY. EACH INDIVIDUAL EQUALLY SPACED TIE-DOWN SHALL BE WITHIN 4'-0" OF THE EQUAL SPACING.
 - 5.3. TIE-DOWNS TO STABLE CONCRETE SHALL BE EITHER A MMA-18-THD1.5 FOR PRE-POURED CONCRETE OR A MMA-42-2 10-PDH FOUR INTO THE CONCRETE, NUMBER OF ANCHORS PER
 - 5.4. ANCHORS (GW-1 ROCK ANCHOR).
 - 5.5. INSTALL GROUND PORTION OF THE ANCHOR PRIOR TO SETTING THE BUILDING, CONNECT ANCHOR TIES TO BUILDING ONLY AFTER BUILDING IS FULLY BLOCKED AND LEVELED.
 - 5.6. INSTALL ALL SPECIALTY ITEMS PER THE MANUFACTURER'S RECOMMENDATIONS. SEE INSTALLATION INSTRUCTION MANUAL.
6. VENTING:
 - 6.1. PROVIDE UNDER FLOOR VENTILATION PER IBC CODE AND LOCAL REQUIREMENTS AT 1 NET SF OF VENTILATION PER 150 SF OF FLOOR AREA.
 - 6.2. IF A CLASS I VAPOR RETARDER (5 MIL POLYETHYLENE) IS INSTALLED THE RATIO MAY BE INCREASED TO I_{500} .
7. ACCESS:
 - 7.1. PROVIDE ACCESS TO THE UNDER FLOOR AREA PER THE CODE.
 - 7.2. PROVIDE 18" MIN. CLEARANCE FROM SOIL TO UNDERSIDE OF ANY UNTREATED WOOD MEMBER.
 - 7.3. PROVIDE 12" MIN. CLEARANCE FROM SOIL TO UNDERSIDE OF ALL BUILDING MEMBERS.
8. SITE CONDITIONS:
 - 8.1. FOUNDATION SUBGRADE TO BE UNDISTURBED NATIVE SOILS OR STRUCTURAL FILL, COMPACTED TO 95% OF THE STANDARD PROCTOR DENSITY PER ASTM D-698.
 - 8.2. SLOPE FINISHED GRADE AWAY FROM THE BUILDING FOUNDATION AT A MIN. GRADE OF 5% FOR THE FIRST 10 FEET AND 2% THEREAFTER TO A SUITABLE DISCHARGE.

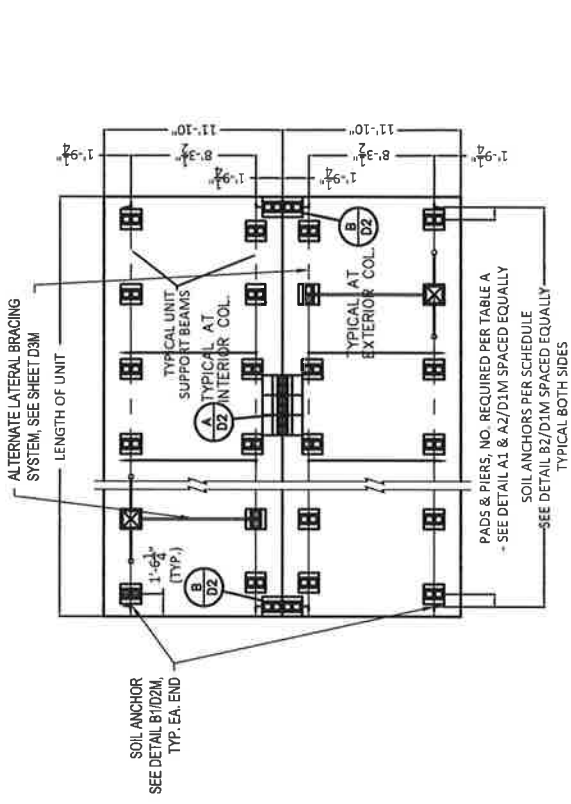

1 FOUNDATION PLAN
SCALE: 1/8" = 1'-0"

TABLE A MODULE RAIL PIER/PAD SPACING

INSTALL PIER/PADS UNDER EACH CHASSIS SUPPORT RAIL, SPACED EQUALLY BETWEEN END PIERS. SEE DETAILS SHEET D1M
INSTALL SOIL ANCHOR HOLD-DOWN ASSEMBLIES EACH OF FOUR WALLS, SPACED ASSEMBLIES EQUALLY BETWEEN END HOLD-DOWNS. SEE DETAILS SHEET D1M

WIDTH OF UNIT	LENGTH OF UNIT	# PADS & PIERS	ROOF LOAD 30 PSF	OUTSIDE RAILS/INSIDE RAILS	LATERAL ANCHORS (OR) BRACES EA SIDE	110 MPH WIND EXPOSURE EA END	C
24'-0"	40'-0"	10/7	10/7	3-2	3-2	3-2	3-2
24'-0"	60'-0"	14/10	15/10	5-3	5-3	4-2	4-2
36'-0"	60'-0"	14/10	15/10	5-3	7-3	3-2	5-3
48'-0"	60'-0"	14/10	15/10	6-3	7-4	6-3	6-3
60'-0"	60'-0"	14/10	15/10	6-4	8-4	6-4	6-4
72'-0"	60'-0"	14/10	15/10	9-4	9-4	9-4	9-4
84'-0"	60'-0"	14/10	15/10	10-5	10-5	10-5	10/5



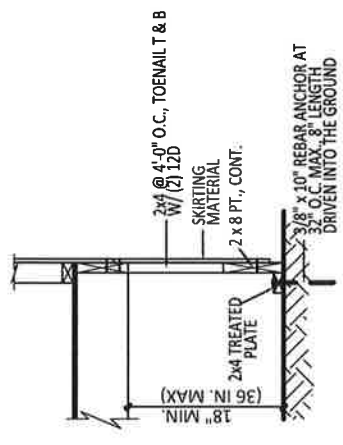

C1 SKIRTING DETAIL-NONBEARING
 N.T.S.

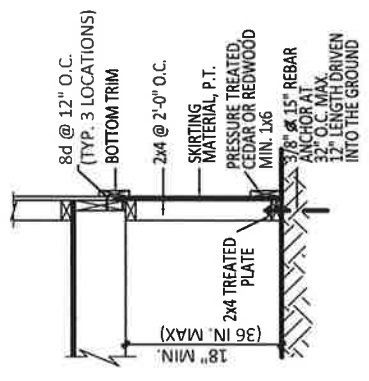

C2 SKIRTING DETAIL-STRUCTURAL
 N.T.S.

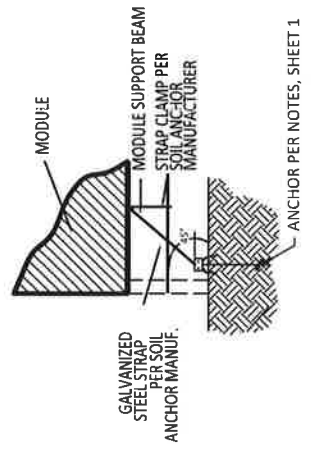

B1 SOIL ANCHOR-ENDWALL
 N.T.S.

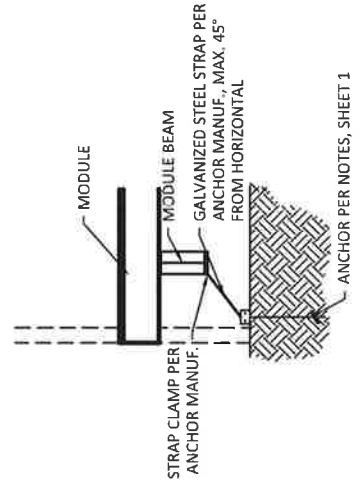

B2 SOIL ANCHOR-SIDEWALL
 N.T.S.

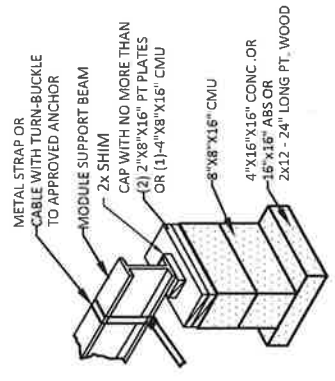

A1 CMU PIER
 N.T.S.

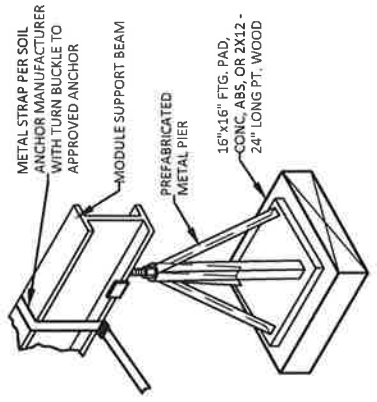

A2 PAD & PIER
 N.T.S.



EXTERIOR

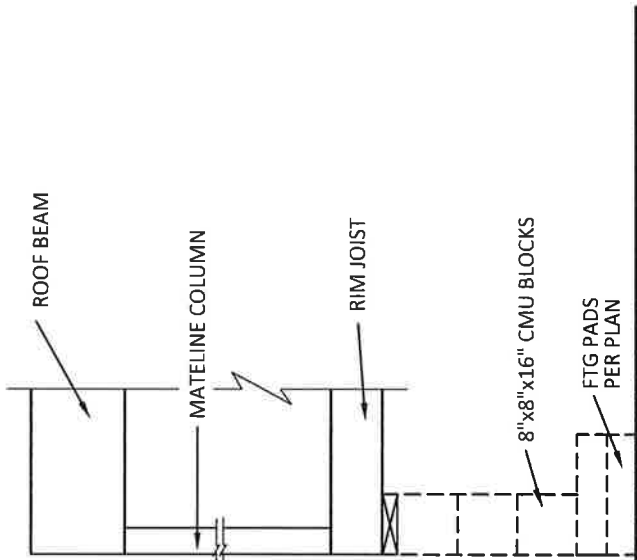

B EXTERIOR COLUMN SUPPORTS
 N.T.S.

INTERIOR

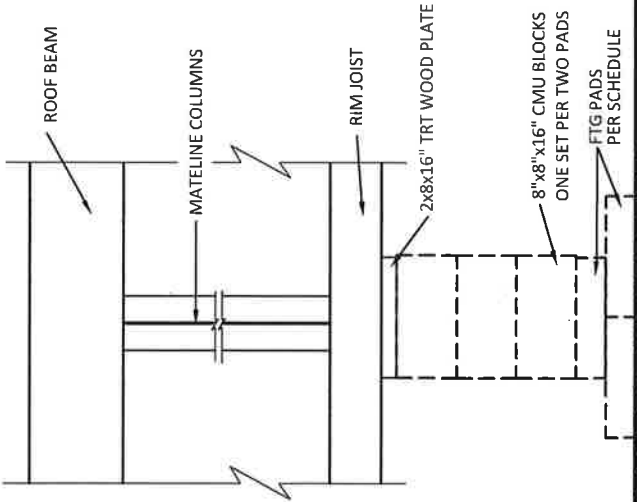

A INTERIOR COLUMN SUPPORTS
 N.T.S.

PADS REQUIRED AT ROOF BEAM SUPPORT COLUMNS
 30 PSF ROOF LIVE LOAD
 - 12-FT. MODULES: (2) 16" x 16" PADS PER 10'-10" EFFECTIVE SPAN
 - 14-FT. MODULES: (2) 16" x 16" PADS PER 9'-0" EFFECTIVE SPAN
 40 PSF ROOF LIVE LOAD
 - 12-FT. MODULES: (2) 16" x 16" PADS PER 8'-6" EFFECTIVE SPAN
 - 14-FT. MODULES: (2) 16" x 16" PADS PER 7'-4" EFFECTIVE SPAN
 EFFECTIVE SPAN = $\frac{1}{2}$ BEAM SPAN EACH SIDE OF COLUMN

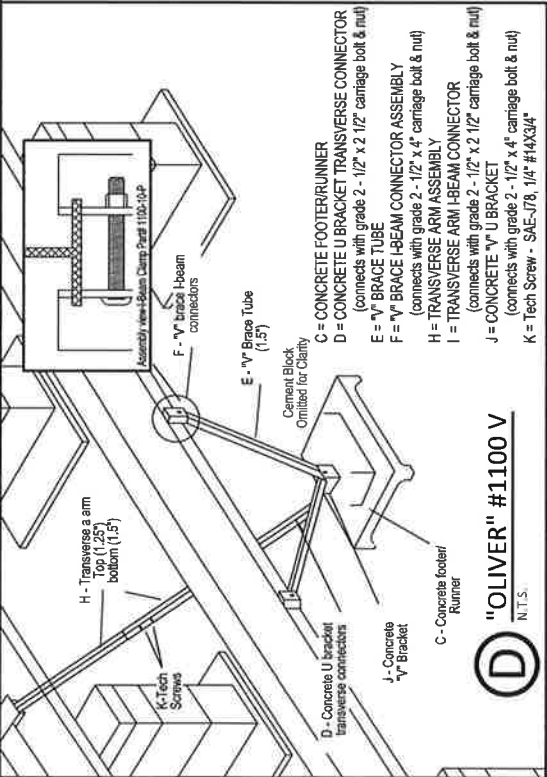
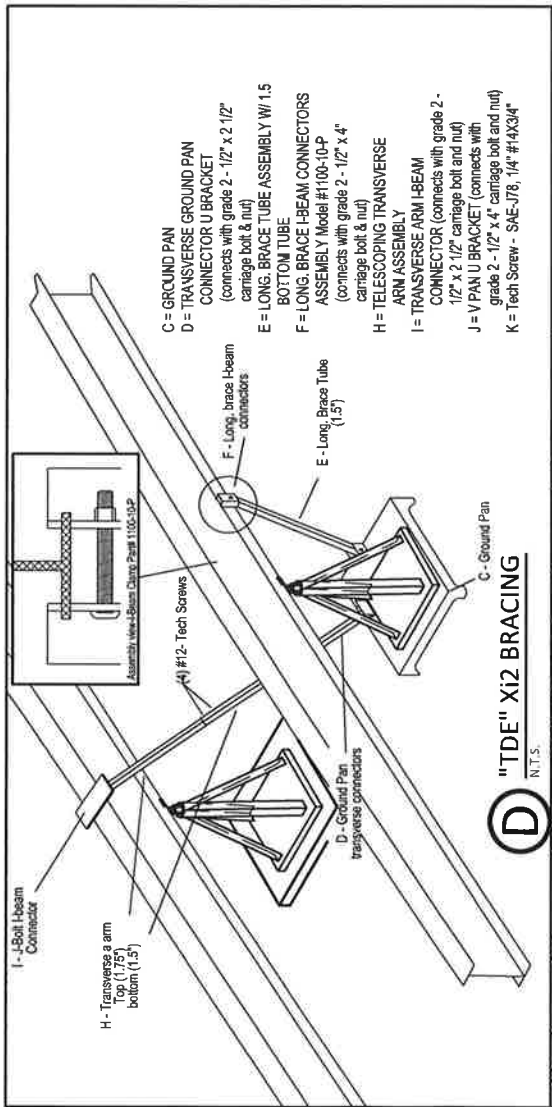



BENTON COUNTY FIRE PROTECTION DISTRICT NO. 4

NOTICE OF SPECIAL MEETING

The Board of Fire Commissioners of Benton County Fire Protection District No. 4 has called a Special Board Meeting on June 13, 2019. The meeting will take place at **1800** hrs. at 2604 Bombing Range Rd, West Richland, WA 99353, to take action on or discuss the following item(s):

- Executive session per RCW 42.30.110 (g) to review the performance of a public employee.

Dated: 06/11/2019 at 1500 hrs.

SLITA BRADLEY/DISTRICT SECRETARY